



# OPERATING MANUAL

Mobile Restroom Trailers

Forest River Cargo, 3731 California Rd., Elkhart, IN 46514

# **Welcome to Forest River!**

Forest River is one of the world's largest manufacturers of Cargo, Auto Transport, Specialty Trailers, and Recreational Vehicles. At Forest River, we have attempted to design and manufacture a very functional and serviceable portable Restroom facility. Using the best materials we have been able to obtain, we feel that this product will offer durability and performance for a long period of time.

Thank You

# Table of Contents

- Knowing Your Trailer
- Pre-Trip Check List
- Hitching Up
- Set Up
- Instructions For Lowering And Raising An ADA Unit
- Testing And Adjustments
- Operation
- Tear Down / Dismantling
- Winterizing
- Routine Trailer Maintenance
- General Trailer Maintenance
- Trailer Maintenance Record
- Warranties, Parts, & Service
- Reporting Safety Defects

# Knowing Your Trailer

Please review the following pictures and descriptions so you can familiarize yourself with the various components of your trailer.



View Of The Trailer With Steps And Porches Retracted. The Railings Are Stored In The Mechanical Room



Side View Showing Steps, Railings, & Porches Assembled



Rubber Draw Latch-Holds The Porch Steps In Retracted Position



Bracket Holding Porch In Retracted Position



Leveling Foot For Steps

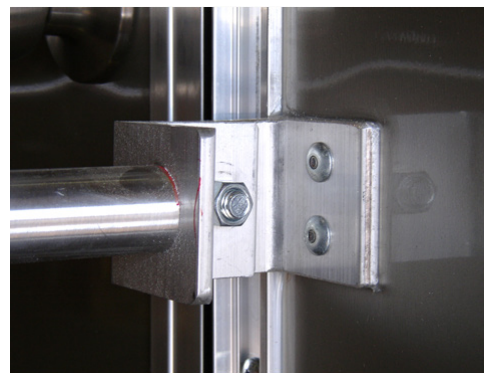

Railing Installed At Top



View Of Rail Locking Pin At Bottom



Leveling Jack



Exterior RV Style Electrical Cord Hook-Up



City Water Fill



Front Of Trailer Showing Pump Out Valve  
And Wash Out Port



Vacant / Occupied Lights

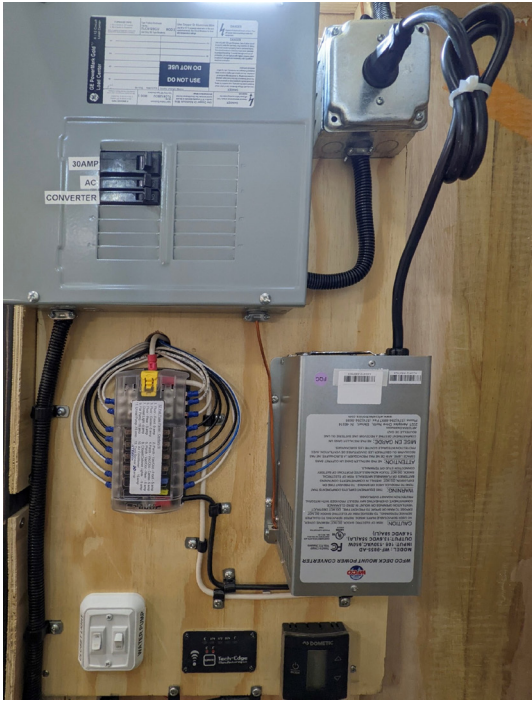

Electrical Panel

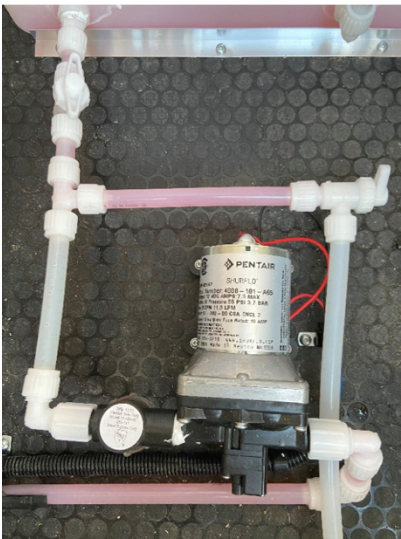

Freshwater Pump (Exposed)

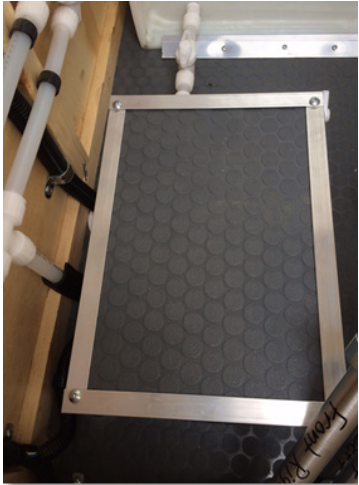

Freshwater Pump With Cover



On-Board Freshwater Tank Showing Fill Cap And Water Level Sight Tube



Urinal Pump



Accumulation Tank (Mechanical Room)



Roof A/C And Ducts



A/C Control



View Of Women's Restroom



ADA Switches

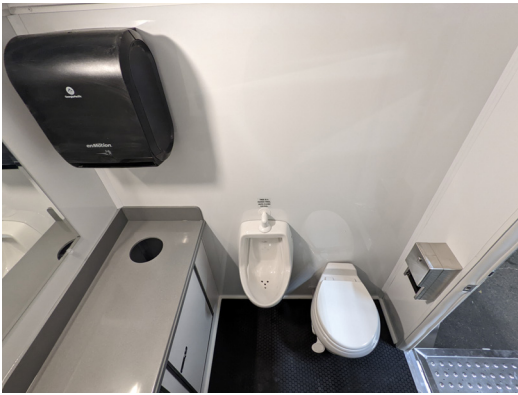

View Of Men's Restroom



Overhead View Of Vanity



View Of Trash Collection Receptacle In Locking Base Cabinet



Timed Faucet, Sink, And Soap Dispenser



Paper Towel Dispenser And Trash Disposal



Toilet Paper Dispenser



Vacant / Occupied Slide Bolt



# Pre-Trip Checklist

This is the most important thing you should look at before using your new trailer. Please take your time, and make sure you go over this list completely! A description of how these parts work and how they should be properly checked is included in the Trailer Owner's Manual.

- Hitch and coupler w/ safety pin
- Safety chains crossed and secured properly
- All jacks are up
- All running lights, brake lights, and turn signals functioning
- Brakes, brake controller, and breakaway system
- Proper tire pressure and tire condition on trailer and tow vehicle
- Wheel lug nuts tightened
- Doors, windows, and roof vents closed and secured
- Tie-down Steps, Porches, & Railings
- Proper load distribution
- Both Fresh & Waste Water tanks must be empty prior to transporting the trailer.

**Always remember that some common causes of accidents are (1) driver error, (2) failure to match your road speed with road conditions, and (3) improper loading.**

**Safety Chains:** Be sure to always connect the safety chains by crossing them beneath the coupler when hooking up your trailer. Crossing your safety chains will create a cradle to catch the tongue in case of disconnect from the hitch. Allow enough chain for turning, if too long, then they should be shortened (just simply twist them). If they look like they have been over-stressed, they should be replaced. **In some states it is required by law that you cross your safety chains.**

**Brakes:** Forest River trailers come with many different types of brake options. Repair and service information for each available type of brake can be found in the Axle Manufacturer's Service Manual. Please follow all of the Axle Manufacturer's instructions concerning brakes. Remember that failure to follow instructions could result in loss of warranty. Brakes on new trailers usually tend to "pull" or pulsate, but don't worry, this is normal. Remember that not all Forest River trailers are equipped with brakes.

**Tire Pressure:** The proper air pressure for your tires is printed on the sidewall of the tire. Air pressure should always be checked when tires are cold for the most accurate reading. You must not raise or lower your air pressure to meet your load. Serious injury may result in under and over inflation. Excessive wear and tear will also result if recommended pressure is not met. You must avoid, if possible, any chuckholes, curbs, or other hazards in the road.

**Hitch and Coupler:** You must correctly match your tow vehicle to your trailer. It is essential that your tow vehicle can handle the total trailer weight (GVWR). You should also check to see that the hitch weight carrying capacity of your tow vehicle matches the loaded tongue weight of your trailer. If you have a brake controller, then you want it to match with the number of braking wheels on your trailer. The electrical wiring of your tow vehicle needs to match the wiring on your trailer. **It is very important that the ball on your hitch matches the coupler size on the trailer.**

**Proper Load Distribution:** All Forest River trailers are carefully designed to maintain a proper hitch weight when the trailer is evenly loaded. If improperly loaded, your trailer can become very unstable and difficult to control on the road. Uneven loading and improper hitch weight can make steering difficult and result in unsafe stopping and braking of the trailer and the tow vehicle. For bumper-hitch trailers, always load 60 percent of the cargo weight evenly in front of the axles. For Goosenecks, load 70% of the weight in front of the axles. This will result in an approximate 10 percent of the loaded trailer weight on the hitch. Hitch weight should never be less than 10 percent of the gross vehicle weight (trailer plus payload).

**Distribute Load As Shown Below:**

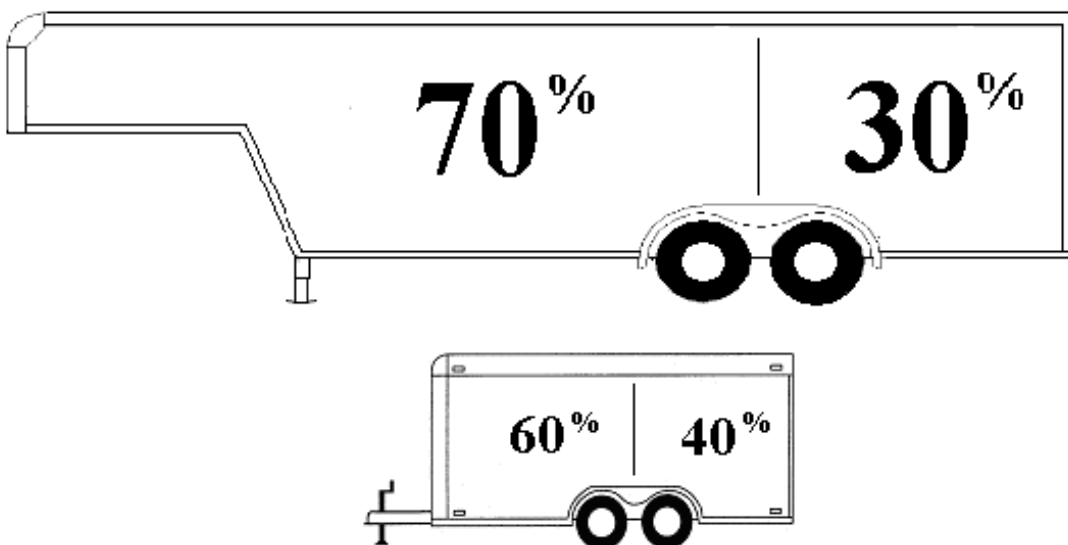

**Tips For The Beginner – Turning & Backing Up**

Always remember when turning, that the trailer makes tighter and quicker turns than your tow vehicle. To help compensate for this, please allow as much space as possible when turning so that the trailer will not jump the curb or hit any obstacles. When backing up place your hand on the bottom of the steering wheel while watching in your outside mirror. If you want the rear of the trailer to turn right move your hand right, and if you want the rear of the trailer to turn left then move your hand left. Please always remember to check the area behind the trailer to see that there are no obstacles in the way before you begin to back up.

# Hitching Up

To ensure safe towing, make sure you have a suitable vehicle, hitch, and trailer. It is the trailer owner's responsibility to correctly match the combination of tow vehicle and trailer. Contact a hitch specialist, who can help you match your tow vehicle and hitch, and equip you with a properly installed brake controller. **Make sure the ball on your hitch matches the coupler size on the trailer.**

- Use the jack to raise the coupler high enough for the hitch ball to slip beneath.
- Release the coupler-locking device (raise the lever).
- Back your tow vehicle into mounting position.
- When properly aligned lower the coupler onto the ball.
- Continue raising the jack until it is fully raised.
- Latch the coupler-locking device (It is very important to lower the lever and insert a pin in the lock hole).
- Connect the safety chains by crossing the chains beneath the coupler and attach them to the tow vehicle. Allow enough slack for turning, but no dragging (Tip: if chains are too long, simply twist them).
- Connect the electrical plug on the trailer to the plug on the tow vehicle. Check to make sure that all running, directional, and brake lights are functioning.
- Load properly approx. 60% in front of the axles (you want 10-15% of the trailer and load weight on the hitch), balance the load side to side, and secure it (you don't want it getting loose). Don't overload, go by acceptable payload ratings or you may void the warranty.
- Take a trial run and familiarize yourself with the handling characteristics of our tow vehicle and trailer.

## Electrical Wiring

You must have the correct vehicle wiring when using your trailer. Trailers are equipped with brakes and a 7-way plug. Don't forget that a ground wire running from the plug back to the frame of the tow vehicle must be incorporated into proper tow vehicle wiring. **WARNING: Safety chains, hitches, and couplers DO NOT provide adequate grounding by themselves and can cause electrical failures.**

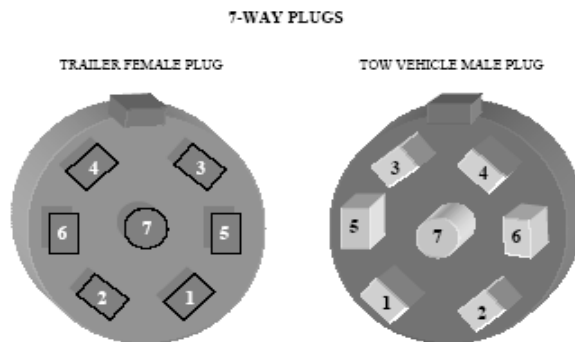

Number	Wire Color	Function
1	White	Common Ground
2	Blue	Electric Brakes
3	Green	Tail, License, & Running Lights
4	Black	Battery Charge, Hot, & Dome
5	Red	Stop & Left Turn Signal
6	Brown	Stop & Right Turn Signal
7	Yellow	Extra Auxiliary

# Set-Up

Please follow these step-by-step procedures. Set-up time will be about ½ hour.

## Leveling Your Unit

Thoroughly inspect the site location. The site should be level and have proper access to water and electricity. Consider proper facing of the unit for convenient access and adequate drainage.

After positioning the unit, block the wheels prior to disconnecting from the tow vehicle.

Level the unit from front to back using the front tongue jack. Level the unit side to side by using the scissor jacks located on each corner.

When setting up the trailer for use, it is important that the stabilizer jack on each corner be lowered and the trailer leveled. Levels are located on each side of the trailer near the wheel fenders and on the front and back of the trailer.

## Step Assembly – Century Series

(Tools required: 9/16” Box wrench & Ratchet with 9/16” Socket)

**\*\*Do not unlock doors until porches are down and railings are installed\*\***

- Release rubber latch under step
- Unbolt step latch from trailer
- Carefully extend and lower step. Watch for pinch points
- Place sand pad under step legs
- Remove Thumbscrew from rail tube
- Insert railing tube & secure with Thumbscrew
- Fasten railing to trailer at bracket with supplied fasteners
- Repeat for other railing
- Secure by tightening thumb screws

## Step Assembly – Denali/Rainier Series

(Tools required: 9/16” Box wrench & Ratchet with 9/16” Socket)

**\*\*Only unlock the one door at a time to access porches and steps\*\***

**\*\*Care should be taken to insure the door is not damaged during set-up\*\***

- Remove porch and step unit from the men’s room
- Set porch in the channel under the door

**\*\*Immediately install railings on this porch to avoid the rail bracket denting the door and damaging the door closure.\*\***

- Remove Thumbscrew from rail tube
- Insert railing tube & secure with Thumbscrew
- Fasten railing to trailer at bracket
- Repeat for other railing
- Secure by tightening thumb screws
- Repeat the same process for the female room (and exit sides on a Denali)

### **Steps, Porches, And Railings**

It is also important when lowering each porch and step arrangement, to be certain that the porch is properly leveled using the screw jacks on each step. Levels are also provided on each porch for this purpose. Proper leveling of the porches facilitates easier placement of the step to sidewall railing. The railing is attached by removing the two black thumbscrews, inserting the railing into the pockets then reapplying the thumbscrews. The sidewall railing is first inserted into the pocket after removing the thumb screw, then carefully swing the bracketed end of the railing to meet the sidewall bracket, insert a 3/8" x 1" bolt and secure it with a self-locking nut. re-install the thumbscrew.

## **Instructions for Lowering and Raising an ADA Unit**

1. Position unit on a level and flat area.
2. Located in the mechanical room there are three (3) switches that control the electrical jacks that raise and lower the unit.

### **To Lower The Unit:**

1. Use all three switches to raise the unit so that the axle and tires are off the ground.
2. Remove the pins from both sides of the independent axle system.
3. Use all three switches to lower unit so that it rests completely on the ground.
4. Remove the step(s) from the cube(s) and pin them in place. Adjust leveling feet as needed
5. Unbolt and lower ADA platform. Adjust leveling feet as needed.
6. Remove the ramp sections from the ADA cube. Install ramp sections to the ADA platform.
7. Install rails for ramp and platform.

**To Raise The Unit:**

1. Remove rails, ramps, steps. And stow them in their appropriate cube.
2. Raise and bolt the ADA platform in place.
3. Use all three switches to raise the unit completely.
4. Re-insert pins in both sides of the independent axle system.
5. Lower the unit back onto the axle and tires. Continue to retract the roadside and curbside jacks into the full upright stored position.

## Testing and Adjustments

**Testing and Adjustments**

The flushing of the urinal is dependent upon the use of the sink. The sink water is captured in a small holding tank in the mechanical room and is pumped to the urinal when the tank fills. The steps to verify the operation of the bilge pump would be as follows:

1. Open the unit and power it up.
2. Check the breaker box to make sure the breakers are in the “on” position.
3. Either put water to the unit or carry a bucket of water into the men’s cube. Bucket is easiest and quickest.
4. Either hold the faucet open or begin pouring the bucket of water into the sink.
5. Once enough water has gone down the drain, the urinal should flush automatically.

The vacant/occupied light magnet/sensor has built in adjustments. There is a magnet in the slide bolt and a sensor in the door frame that is held in place by backup nuts on each side of the metal plate. The most common adjustment is up/down, but in some rare cases the in/out adjustment has been needed.

**The steps to adjust the magnet up & down are as follows:**

1. Locate the magnet in the tip of the slide bolt.
2. The magnet is positioned in the middle of the slide bolt from the factory.
3. Check the current position of the magnet and adjust up or down to meet the sensor. This adjustment can be done with a small standard screwdriver. Use a straight edge to show the position of the sensor on the slide bolt and then adjust accordingly.
4. TEST

The steps to adjust the sensor in & out are as follows:

1. Remove the strike plate by removing the screws that hold it in place (#2 square head bit)
2. CAREFULLY peel back the door gimp from the door extrusion to expose the door sensor.
3. There are two screws holding the wood/metal plate to the wall stud. Remove the two screws.
4. The in/out position of the sensor can now be adjusted. The slide bolt does not need to touch the sensor, but it does need to be within a quarter of an inch to operate.
5. Return all parts to original positions and TEST.

## **Electrical Hook-Up**

The power connector is located on the (roadside) wall, to the left of the utility door. Connect to a 120 Volt, minimum 30 Amp, GFI, (Ground Fault Interrupter) outlet. Use up to a 100ft long 12 Ga. (minimum) Lifeline. Units with a Water Heater will require two Lifelines. Check for tripped breakers on the breaker panel located inside the mechanical room.

## **Electrical**

The electrical breaker panel is located in the Mechanical Room and is labeled for each individual circuit.

Please note that if your unit features the optional Water Heater, it is important to fill the appliance **BEFORE** turning power on to the unit. Failure to do so, may result in damage to the element.

The Water Pump and Lighting (stall/porch/vacancy/mechanical room) operate on 12 Volts. Power is supplied through the 120V/12V Converter and Fuse Panel located in the mechanical room.

## **Water Hook-Up - City Fill And On-Board**

**City Fill:** Connect to the water source using a 3/4" water hose. Attach the hose to the City Fill water connection located on the roadside wall to the right of the utility door.

All the plumbing originates at the City Fill connection located on the roadside of the trailer. This is a standard 3/4" hose connection. Water is fed from this point into the mechanical room via 1/2" plastic tubing. Items supplied by this tubing include the toilets, sinks, and water heater.

In units featuring the optional water heater, the temperature has been preset to approximately 104°F. The single push to operate faucets will supply warm water only and are timed for approximately 5 seconds. The supply line to the water heater also contains a shut-off valve. This shut-off valve will normally remain open except when performing water heater maintenance.

**On-Board:** The freshwater tank is located in the Mechanical Room and can be filled by removing the fill cap, at the top of the tank. The water level indicator is the vertical clear plastic hose on the face of the water tank. The supply pump will operate based on demand. The expansion tank acts as a reserve, so the pump does not cycle continuously.

The freshwater pump, powered through the 12V fuse panel, has an On/Off switch located directly below the fuse panel.

**Do not transport water to your site.** Fill the tank at the nearest water source to your set-up site. When filling the freshwater tank, make sure the drain valve is in the closed position (turned to the side). Make sure the demand pump power switch is turned on during operation, so that the expansion tank (located above the water tank) is filled intermittently.

### **Shower Model:**

If your trailer is a shower model, most features will be the same as those on a standard restroom trailer. However, the shower model has no designated men's or women's stalls and therefore, none of the stalls will contain a urinal. By virtue of that, any and all components associated with the auto-flush urinal are not included in the shower trailer.

Another difference is the use of a propane heated, continuous flow water heater, which is used to supply hot water to the sinks and showers. **Please read the owner's manual for the water heater to familiarize yourself with its operation BEFORE using it.**

The dual propane cylinders are connected to a single regulator which has a selection valve attached to it. This valve allows you to use one bottle while holding the second bottle in reserve. When the first bottle has been depleted, turn the knob left or right to begin using the second bottle. It is then advised that you remove the empty bottle immediately for refilling. DO NOT wait until the second bottle is depleted as doing so will render the trailer unusable with regard to having hot water available.

The thermostat for the water heater is located in the mechanical room on the electrical panel board and is set to a temperature of 104°F. The shower valves are of the pull and release style and will only release water when the valve is turned.

Behind the small access door on the rear of the trailer is a spigot and a large red handled valve. When the large valve is in the vertical position, shower water will drain into the waste tank. If the large valve handle is in the horizontal position, shower and sink water is diverted to the spigot valve. By connecting a garden hose to this valve and extending it past the side of the trailer shower water can be drained onto the ground. **Be certain that local laws allow this action before attempting this diversion.** Once the garden hose is attached, open the spigot valve to its full open position.

All other components with the shower trailer are the same as on a standard restroom trailer and should be viewed as such for general hook-up, plus operating and winterizing procedures



# Operation

## **Air Conditioning / Heating**

Climate Control is provided via a roof air conditioner and a heat strip. The cooling and heating controls are located inside the mechanical room and are mounted on the ceiling. Refer to A.C. Manual for operation.

The air conditioner is located in the mechanical room and operate on 120 volts. The controls for the unit are located on the underside of the air conditioner. The unit has three fan speeds; Low, Medium, and High. Heat is introduced into the unit by switching the control knob to the “Heat” position.

## **Monitoring the Waste Tank**

The Wastewater tank has an LED tank level monitor located in the mechanical room. The display panel is at the bottom of the electrical board below the closet light and water pump switches. When the button is pressed, the last illuminated light will indicate how full the waste tank is.

The toilets drain directly into the waste tank. The sinks drain into a sump pump located just inside the mechanical room. The sink water is used to flush the urinal in the men’s stall, which is then drained to the waste tank through the waste tank vent pipe.

The toilets are foot operated. The shut off valves for the toilets are located in the mechanical room. In addition, each sink or water heater also has a shut-off valve which is located under each vanity.

Add the appropriate odor control and waste digesting chemicals to the waste holding tank

Prior to winter storage, the water heaters, freshwater tank, and expansion tank, should be drained of any water, and charged with RV antifreeze.

# Tear Down/Dismantling

After cleaning and washing down the entire interior, follow the step-by-step procedures that follow.

Turn off the climate control by using the control in the mechanical room. You can also accomplish this by turning off the breaker on the breaker panel.

Disconnect the Electrical power supply.

Disconnect the City Fill water supply.

If allowed, drain the On-Board Freshwater Holding Tank. Remove the fill cap for venting.

Tear down steps and porches by following the set-up instructions in reverse making sure to always lock the doors when the railings are removed.

Crank all four, scissor jacks completely to the up position.

## **Draining The Waste Holding Tank**

Contact your waste removal source. When scheduling your on-sight waste removal, inquire as to the size of their waste hose connection. A 3" connection is the most common, however, 2" connections are widely used and an adapter will be required.

The waste holding tank is emptied, by connecting the 3" septic waste hose to the quick connect drain valve. The valve is located at the front of the trailer, is opened by rotating the yellow handle counter-clockwise. Lower the front of the unit with the tongue jack for optimum drainage. Avoid interfering with the waste hose connection.

For the rinsing out of the waste tank, remove the 1" wash out plug. The plug is located at the front of the trailer to the left of the waste tank access valve.

**The waste holding tank is not designed to be transported without being emptied first. Transporting this tank unemptied will void your warranty.**

## **Waste and Freshwater Tanks**

Both tanks must be empty prior to transporting the trailer. It is also suggested that a waste digesting chemical be added to the waste tank after every other pumping.

## **Doors**

The "in-use" lock is the slide bolt located inside the door above the door knob. A label on each slide bolt indicates the locked and unlocked position of the bolt. When the slide bolt is moved into the locked position, the bolt activates the occupied light changing it to red (occupied). When the slide bolt is moved back to the unlocked position, the light will change to green (vacant). Each door can be key locked from the outside for security and for transporting.

## **Mirrors, Soap, and Towel Dispensers**

All mirrors are made of shatter-proof glass. Care should always be taken to avoid allowing any liquid or substance to contact the edges of the mirror. Continuous use of household cleaners can result in edge damage as many contain chemicals such as chlorine, alkali or sulfuric acid, which can be harmful to mirrors.

Towel Dispensers use rolls of paper towels that are 10" wide. (Georgia –Pacific #GP-89460)

Soap dispensers use any liquid soap.

# Winterizing

## Winterizing Via City Water Fill

Turn off and disconnect city water supply.

Bleed any remaining pressure in the system by flushing toilets

Connect RV hand pump (purchased separately) to city fill connection. Open cabinet in front module then hold faucet open until antifreeze is visible in the water heater input line. Repeat this process in each module. The plumbing tubes are clear, so you can observe the progress of the pink antifreeze as it moves through the water system. Note: RV non-toxic antifreeze and Hand pumps can be found at any RV Supply Center.

Flush each toilet until antifreeze is visible.

Pour approximately 1 quart of non-toxic antifreeze into each sink. Use enough antifreeze to fill the sump pump (as all sinks drain into the sump pump and the drainage is used to auto-flush the urinal). Filling the sump pump will auto flush the urinal and antifreeze should be visible in the urinal.

Verify that antifreeze is visible in all water lines and toilets, then disconnect the hand pump.

## Winterizing Via On-Board Freshwater System

Adjust the stabilizer jacks so the trailer is leaning towards the roadside, this will allow the water to drain properly.

Open the drain valve on the On-Board Freshwater holding tank. Vent the tank by removing the fill cap.

After the tank is empty, close the drain valve and reinstall the fill cap.

Pour 5 gallons of RV pink non-toxic antifreeze into the On-Board freshwater tank.

Turn the water pump on and follow all previous instructions for winterizing Via City Water Fill. Turn the pump switch off.

## 3 Season Model (Rated to 30°F)

If your trailer is a 3 season model it will contain the following options:

- Each waste tank will have a blanket heater in the bottom of the tank. This heater is thermostatically controlled by a sensor located on the side of the tank. The sensing device is set to turn on at 35°F and deactivate the heater at 45°F. There is also a switch on the electrical panel in the mechanical room that will also deactivate these heaters, if so desired.
- Each restroom has a kickspace, electric heater installed at the bottom of the cabinet face. There is a breaker in the mechanical room that will also deactivate these heaters, if so desired.

### **3 Season Shower Model (Rated to 30°F)**

If you have a 3 Seasons shower model, in addition to the 3 Seasons components above, there will be slight differences in the water heater system. The water heater is on the front of the trailer and operates in temperatures as low as 30°F. The drain options for the water heater are manual and the unit must be drained before incurring any temperatures below 30°F. Please refer to the water heater operating manual for instructions.

### **Arctic Model (Rated to -20°F)**

If you have an Arctic model, your unit is equipped with the following heat items to help keep your unit warm in cold weather. In the mechanical room, there is an LP furnace that is controlled by a thermostat on the wall. The LP bottles for the furnace are mounted on the front of the unit and their levels will need to be monitored throughout the rental period. The furnace is ducted to each restroom and into the mechanical room. The vent into the mechanical room is adjustable and will need to be adjusted to meet your specific need. The larger the opening, the warmer the mechanical room and colder the restrooms. The smaller the opening, then the reverse will be the case. The waste tanks are heated by blanket heaters on the bottom of the tank. These heaters are thermostatically controlled by a sensor located on the side of the tank. The sensing device is set to turn on at 35°F and deactivate the heater at 45°F. There is also a switch on the electrical panel in the mechanical room that will also deactivate these heaters, if so desired.

### **Arctic Shower Model (Rated to -20°F)**

If you have an Arctic shower model, in addition to the Arctic components above, there will be slight differences in the water heater system. The water heater is in the mechanical room rather than on the front of the trailer. This is to prevent freezing during cold weather and to allow the addition of some freeze prevention items. These items include two solenoid valves and a check valve. When the water heater is turned on and the trailer has electrical current supplied to it the water heater will monitor itself and circulate warm water if the temperature is approaching freezing. However, if for some reason power to the trailer is disrupted, the large brass solenoid will open and the smaller black solenoid will close. The smaller solenoid will prevent water from entering the water heater and the large brass solenoid will dump any water in the heater, preventing freeze up. When power is reapplied, the valve will reopen/close and normal operation can resume. Please note that the solenoid valves will be warm or even hot to the touch during normal operation. Also, if during start up the brass valve is leaking water, simply tap the valve with the handle of a screwdriver or a small plastic mallet, it should seat the valve and stop the water flow. Make certain that the water heater is plugged into an active source and that the breaker and switch are in the on position.

# Routine Trailer Maintenance

*Here is a list of some checks you will want to do every trip and every 3 months or 3,000 miles.*

<b>Check These Items:</b>	<b>How To Check:</b>	<b>Every Trip</b>	<b>Every 3 Months Or 3000 Miles</b>
Tire Pressure	Inflate all tires to the proper pressure	X	
Wheel lugs, nuts, and bolts	Tighten to proper torque specifications	X	
Coupler ball or 5th wheel pin	Check for unusual wear, sufficient lube and lock mechanism	X	
Safety chains and hitch ball	Check for unusual wear on chain links and hitch ball	X	
Coupler	Check the safety pin to make sure it is fastening properly	X	
Brakes	Check operation and proper adjustment	X	
Breakaway battery and switch	Check the battery in the breakaway system regularly	X	
Doors, windows, and vents	You must close all doors, windows, and vents before travel	X	
Welds	Check welds for cracking and separations		X
Hinges	Lubricate w/ light oil		X
Tie downs, E-Track, and d-rings	Check to make sure the hardware has no cracks and is fastened tight		X
Lights	Replace spent bulbs and fix any broken lights	X	
Load Distribution	Make sure cargo weight is properly distributed	X	

# General Trailer Maintenance

## Aluminum Rims

Your aluminum rims have a clear coat on them so they will last longer through harsh conditions. Make sure you use a very gentle cleaning compound so it will not hurt your rims. Never use any cleaner that contains lye or is acid-based. If you use a lye- or acid-based cleaner it will ruin the finish of your rims. Not all trailers come with aluminum rims.

## Brakes

Your trailer brakes must be inspected and serviced every three thousand miles or once a year. Remember- the more you use it the more you will want to have your brakes checked. If you are not sure about anything remember to look at your Axle Manufacturer's service manual.

## Coupler

Check your coupler before every trip. Look to see if there are any cracks and that the locking mechanism is in proper working order.

## Doors

Check your door hinges every 3,000 miles or 3 months.

## Exterior Aluminum Skin

Please treat the outside of the trailer as you would your car. Use mild soap when washing, and if you desire to wax use an automotive-type wax. Proper care and maintenance will ensure your trailer's color and the durability of its finish.

## Floor

To keep your floor in tip-top shape, avoid prolonged exposure to water. To make your floor last longer simply use a mild floor cleaning solution.

## Frame Maintenance

Over time road use will begin to chip away at the factory-protected underside of your trailer. This is where trailers receive the most punishment. Gravel, rocks, and any loose road debris are thrown up and hit the bottom of your trailer. You need to check the underside of your trailer at least once a year or every 3,000 miles. If you notice any bare spots please touch up with an automotive undercoating or matching frame paint.

## Roof

Inspect your roof at least once a year. Do not let ice and snow build up on your roof. If you notice spots where heavy snow conditions exist sweep it off right away! If you have any loose material on roof, clean and follow with a roof coating. **Do not haul items on your roof if you do not have a roof rack.**

## Welds

Please check your welds every 3 months or 3,000 miles for any cracks or fractures. **If you notice any cracks or fractures please contact your Forest River dealer immediately.**

## Lug Nuts



Check lug nut tightness before your first trip, after 50 miles, 75 miles, and 150 miles. You will want to recheck at least every 3 months or 3,000 miles. **REMEMBER- wheel lug nuts must be tightened with a torque wrench.** The recommended torque range is 85 to 95 foot pounds.

## Tires and Wheels

Always check your tire pressure before using your trailer. When checking tire pressure always check when tires are cold. If you are not sure of proper pressure, you can find it on the sidewall of your tires. **DO NOT** change your tire pressure for the load of the trailer. If you do, it can cause excessive tire wear and even a blowout. Follow the chart below.

# Tire Inspection

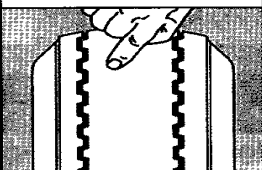
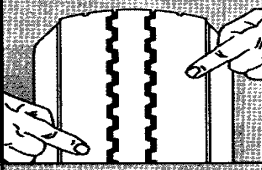
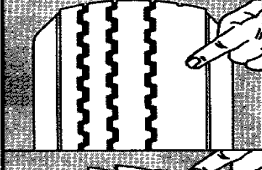
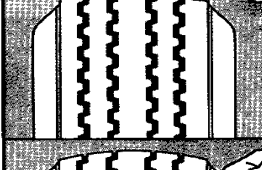
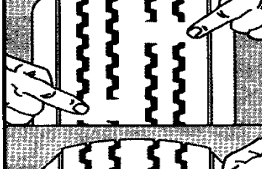
 **WARNING** *When replacing tires consult wheel and tire manufacturers' specifications for compatibility. Improperly matched wheels and tires may fail and cause property damage, serious personal injury, or loss of life.*

	Condition	Possible Cause	Remedy
	Even Center Wear	Over Inflation	Check & Adjust Pressure When Cold
	Inside & Outside Wear	Under Inflation	Check & Adjust Pressure When Cold
	Smooth, Side Wear - One Side	Loss of Camber or Overloading	Check & Unload As Necessary Have Alignment Checked
	"Feathering" Across The Face	Axle Not Square To Frame or Incorrect Toe In	Square Axles Have Alignment Checked
	Cupping	Loose Bearings or Wheel Balance	Check Bearing Adjustment and Wheel & Tire Balance
	Flat Spots	Wheel Lockup	Adjust Brakes





# Warranties, Parts, & Service

## Warranties

For the trailer warranty, refer to the Trailer Owner's Manual. For appliances and other components please refer to the appropriate individual service manuals provided.

## Warranty Department

Forest River Cargo Division  
3731 California Rd  
Elkhart, IN 46514

Phone: 574.266.7539

Fax: 574.266.4596

Email: [cargo16warranty@forestriverinc.com](mailto:cargo16warranty@forestriverinc.com)

## Parts and Service

Forest River Cargo Division  
Parts Department  
3731 California Rd  
Elkhart, IN 46514

Phone: 574.266.7554

Fax: 574.266.7555

Email: [cargo16parts@forestriverinc.com](mailto:cargo16parts@forestriverinc.com)

Note: All components, instructions, and specifications contained in this manual are based on the latest product information at the time of publication. Forest River reserves the right to make changes in materials, equipment, and specifications at any time without notice and assumes no responsibility for any errors in this manual.

## Reporting Safety Defects

If you believe that your vehicle has a safety defect that could cause a crash or could cause injury or death, you should immediately inform the National Highway Traffic Safety Administration (NHTSA) in addition to notifying Forest River, Inc.

If NHTSA, receives similar complaints, it may open an investigation, and if it finds that a safety defect exists in a group of vehicles, it may order a recall and remedy campaign. However, NHTSA cannot become involved in any individual problems between you, your dealer, or Forest River Inc.

To contact NHTSA, you may either call Vehicle Safety Hotline toll-free at 1-888-327-4236 (TTY: 1-800-424-9153), go to <http://www.safercar.gov>; or write to: Administrator NHTSA, 1200 New Jersey Avenue S.E. Washington, DC 20590

You can also obtain other information about motor safety from <http://www.safercar.gov>